



BX1949 Installation Instructions 1995-01 Dodge Ram 1500 1995-02 Dodge Ram 2500 and 3500

Serial No.

Strong As An Ox™ The metal bumper is removed for baseplate installation. Holes need to be drilled. The BX8869 is available for this vehicle. The attachment tabs are 24" center to center and 23 1/2" in height.



1. Mark the center of the bumper brackets on the opening.



3. To remove bumper bracket, use the 18MM socket. It will be necessary to remove bottom carriage bolt with a pry bar. Reinstall bumper brackets to vehicle and center baseplate on brackets, mark and drill holes with the 13/32" drill bit, both sides.



5. Using a clamp, hold lower support to cross member. Drill these holes with the 13/32" drill bit, both sides. Insert item 5 thru baseplate and cross member into item 4. Tighten items 7 and 8, according to drawing on last page.



2. Using the 18MM socket, remove the six metric bolts from bumper brackets while holding metal bumper and set bumper aside.



4. Hold baseplate to align with drilled holes and install items 2, 7, 8, and 13 loosely. **Be sure and use loctite on all bolts before tightening.**



6. Install item 3 using items 9, 10, 11, and 12 to bumper brackets existing hole, and tighten. Using the brace as a template, drill 13/32" hole and fasten with items 5, 6, 7, and 8, both sides. **Be sure and use loctite on all bolts before tightening.**



Strong As An Ox™



7. Install metal bumpers upper carriage bolts and nuts to bracket using the 18MM socket, do **not** tighten.
8. Using the pry bar, reinstall lower carriage bolts and nuts with the 18MM socket, tighten all bolts. **Be sure and use loctite on all bolts before tightening.**
9. The dimensional variations between otherwise identical cars can be considerable. While the location and size of the holes in the baseplate were designed to allow for easy installation, it may be necessary to file a hole slightly to allow a bolt to clear.
10. Install the tow bar and safety cables according to the instructions included in their packages.
11. Do **not** substitute other devices if the tow bar pin and clip are lost.
12. **DEALER OR INSTALLER: BE CERTAIN THE USER RECEIVES THE INSTRUCTION SHEET.**

Tools Required

18MM Socket
9/16" Socket
3/4" Socket

Loctite Blue
Vise Grips

13/32" Drill Bit
Pry Bar



Strong As An Ox™

Parts List

Ref. No.	Qty.	Part No.	Description
1	1	61-5721	Weldment, Base Plate, BX1949
2	4	107-2445	Spacer Tube, BX1949
3	2	102-6213	Brace, BX1949
4	2	102-6212	Backing Plate, BX1949
5	6	201-0443	3/8-16 x 1 Hex Bolt, Grd. 5, ZP
6	2	203-0003	3/8 Flat Washer, ZP
7	10	203-0010	3/8 Lock Washer, ZP
8	10	202-0003	3/8-16 Hex Nut, ZP
9	2	201-0051	1/2-13 x 1 1/2 Hex Bolt, Grd. 5, ZP
10	2	203-0005	1/2 Flat Washer, ZP
11	2	203-0012	1/2 Lock Washer, ZP
12	2	202-0005	1/2-13 Hex Nut, ZP
13	4	201-0444	3/8-16 x 2 Hex Bolt, Grd. 5, ZP
	2	226-0049	Baseplate Safety Cable, 36" CL IV (Not Shown)
	4	229-0512	Quicklink, 1/2, ZP (Not Shown)

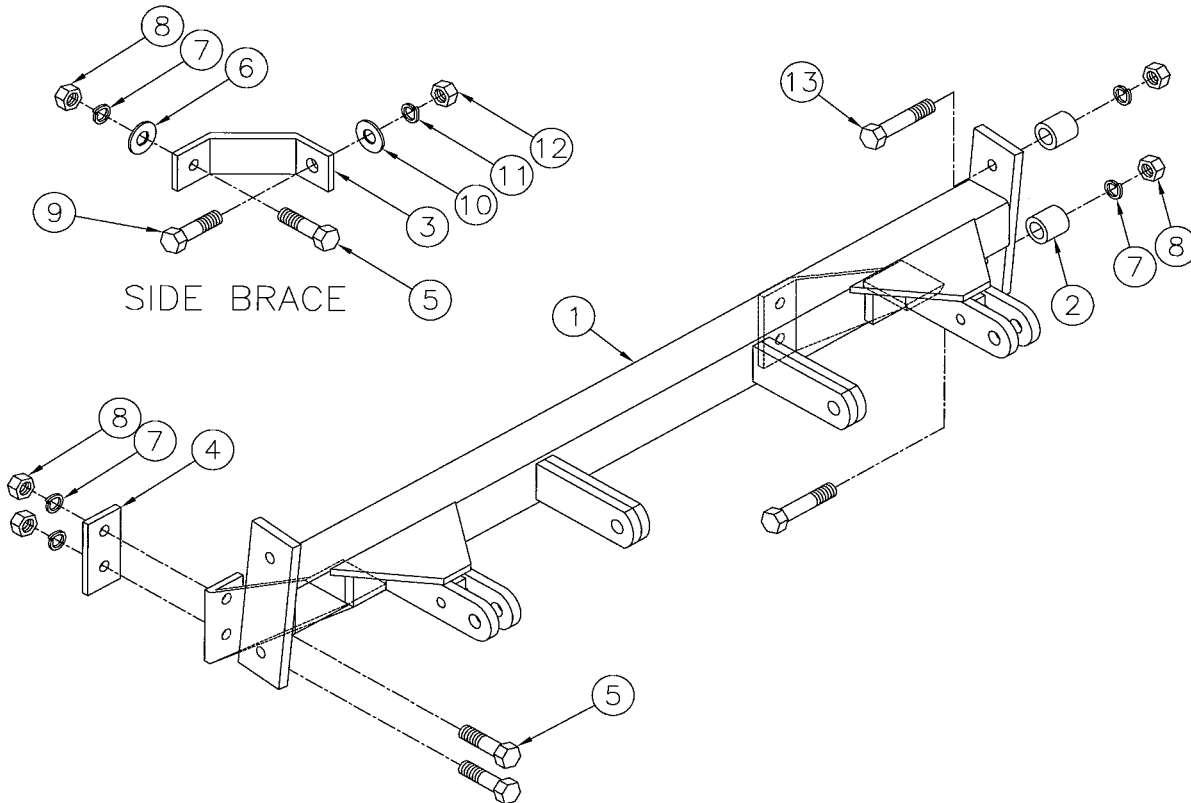

IMPORTANT: Use only genuine factory replacement parts on your Base Plate. Do not substitute homemade or nontypical parts. If a bolt is lost or in need of replacement, for your safety and the preservation of your Base Plate, be sure to use a replacement bolt of the same grade (Usually Grade 5, refer to parts list). Repair parts may be ordered through your nearest **Blue Ox** dealer or distributor.